

DRAWING MADE IN THIRD ANGLE PROJECTION  
 THIS DRAWING IS UNPUBLISHED. RELEASED FOR PUBLICATION .19  
 © COPYRIGHT 19 BY AMP INCORPORATED. ALL INTERNATIONAL RIGHTS RESERVED.

LOC	DIST	REVISIONS					
		ZONE	LTR	DESCRIPTION	DATE	APPD	
G	14			C	REV & REDRAWN PER 0720-0040-93	3-17-93	JMD DAP

**METRIC**  
 DIMENSIONS LISTED IN mm [ INCHES ]

<b>AMP</b> WIRE RANGE	E13288 Listed
16-14HD AWG SOLID OR STRANDED	16-14HD AWG STRANDED
LR7189 Certified	MILITARY P/N AND CLASS
16-14HD AWG SOLID OR STRANDED	NOT APPLICABLE

STAMP AMP 16-14HD\* APPROX AS SHOWN

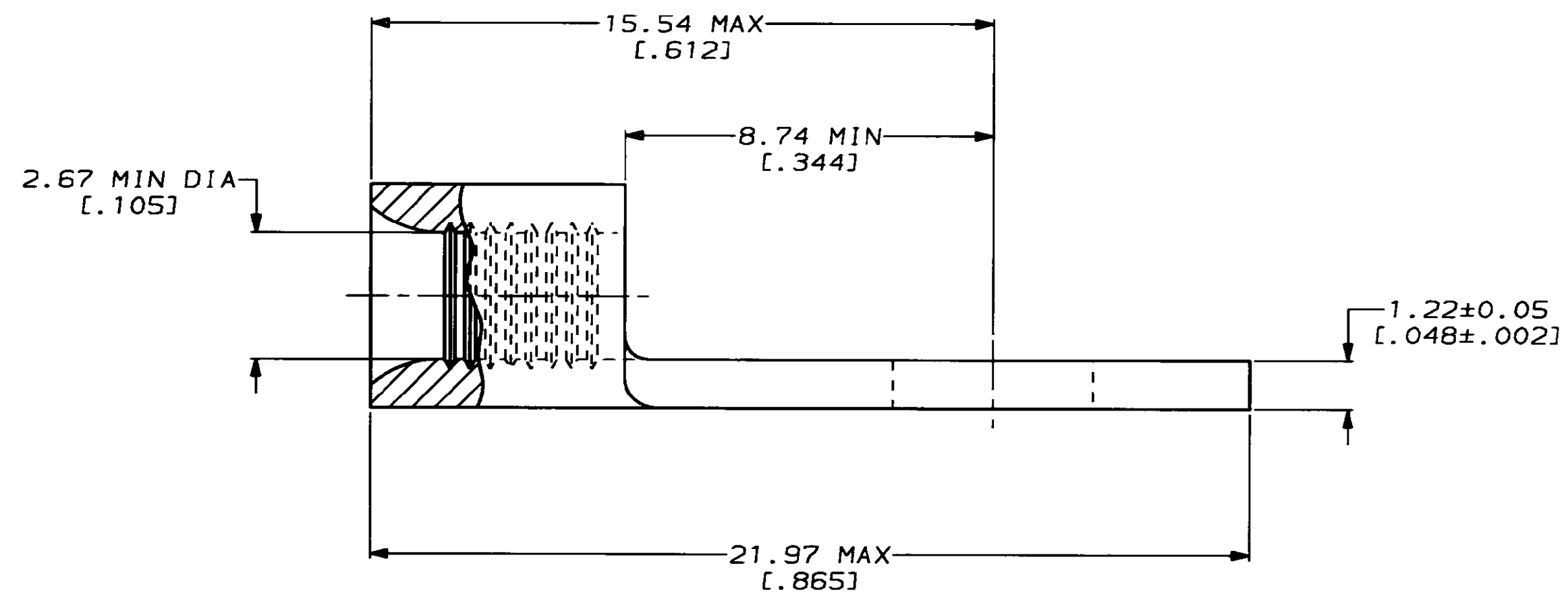
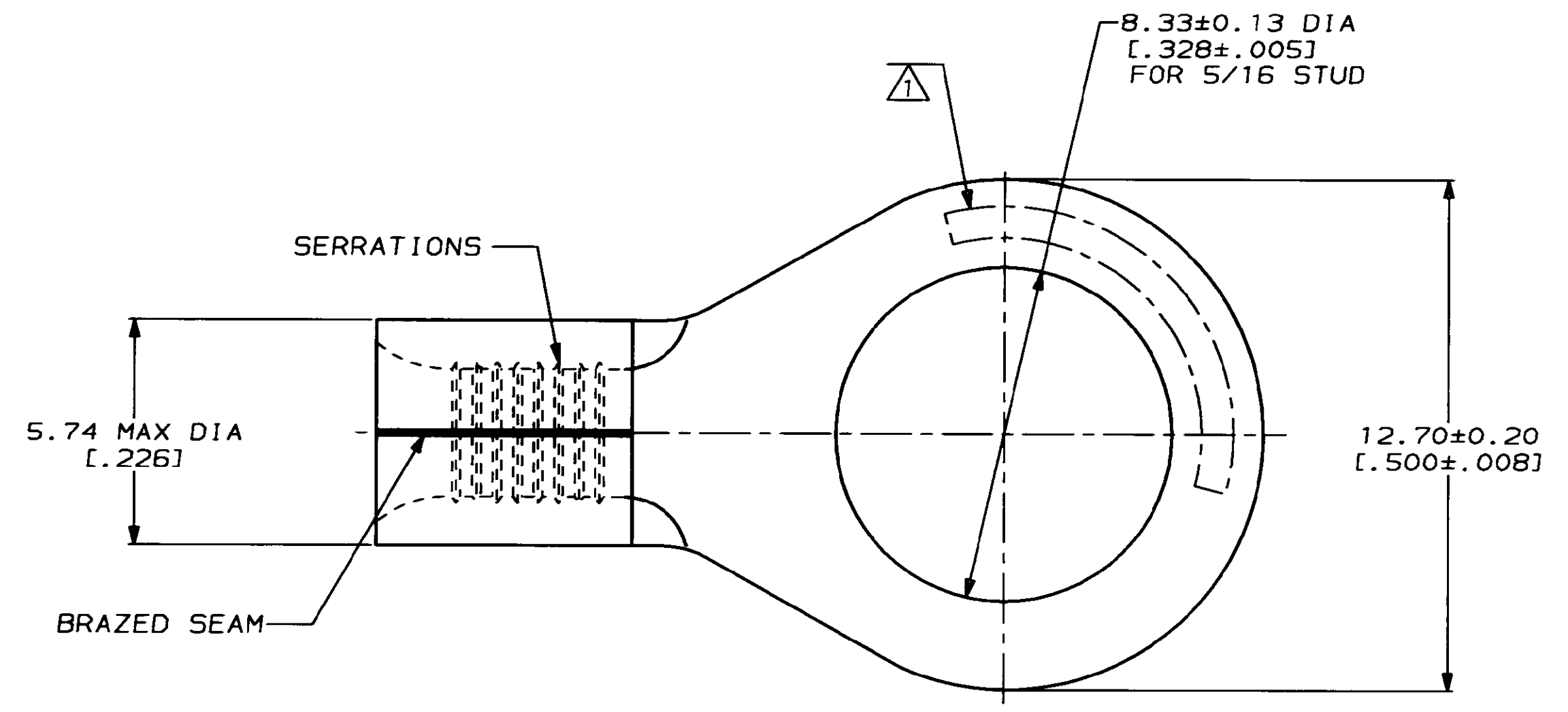

35776  
 PART NO

**AMP INCORPORATED**  
**CUSTOMER SERVICE SYSTEMS**

FOR ADDITIONAL PRODUCT INFORMATION OR COPIES OF DRAWINGS AND TECHNICAL DOCUMENTS	PRODUCT INFORMATION CENTER 1-800-522-6752
FOR APPLICATION TOOLING INFORMATION	TOOLING ASSISTANCE CENTER 1-800-722-1111
FOR ORDER ENTRY	1-800-526-5142

MAX RECOMMENDED OPERATING  
TEMPERATURE:  
170°C MAX

VOLTAGE RATING:  
NOT APPLICABLE

WIRE CROSS SECTIONAL AREA RANGE:  
1.04-2.62mm<sup>2</sup> [2,050-5,180] CIR MILS  
SOLID OR STRANDED

THIS DRAWING IS A CONTROLLED DOCUMENT FOR  
AMP INCORPORATED. IT IS SUBJECT TO CHANGE  
AND THE CONTROLLING ENGINEERING ORGANIZATION  
SHOULD BE CONTACTED FOR THE LATEST REVISION.

DO NOT SCALE PRINT.  
UNLESS SPECIFIED  
DIMENSIONS IN mm [INCHES]  
TOLERANCES ON:  
2 PLC DEC ± -  
3 PLC DEC ± -  
ANGLES ± -

MATERIAL  
COPPER PER  
ASTM B-152  
ANNEALED

FINISH  
TIN PLATE  
0.00254 [.000100] MIN  
THK PER MIL-T-10727

OR 3-17-93  
TA BRINKMAN

CHK 3-17-93  
DA PATTERSON

APPD 3-17-93  
DE MILLER

APPD 3-17-93  
JL MECKLEY

PRODUCT SPEC  
-

APPLICATION SPEC  
-

WEIGHT -

**AMP** AMP Incorporated  
Harrisburg, PA 17105-3608

NAME  
TERMINAL, RING TONGUE,  
HEAVY DUTY, SOLISTRAND™

SIZE C	CAGE CODE 00779	DRAWING NO C-35776
SCALE 8:1	SHEET 1 OF 1	